



clivus
multrum™
WATERLESS COMPOSTING TOILETS

go green pay less no mess



why is clivus multrum™ the best

Because we all want a toilet that is hygienic, odourless, requires minimal maintenance, and still looks great in the bathroom.

Whether you are looking for a cost-effective system, or are fully committed to ecologically and sustainable lifestyles, the Clivus Multrum™ is the BEST CHOICE. If you have a site with limited water supply, or it has poor drainage, maybe the Clivus Multrum™ will work for you too.

We designed it to be all that and more!

Our unique design features mean better performance, resulting in the most reliable and efficient composting toilet.

The Clivus Multrum™ is a self-contained, waterless, odourless toilet treatment system.

It uses no chemicals, heat or water and has no polluting discharge. It can save over 60,000 litres of water per year in the average home and costs far less than regular treatment systems.

The Clivus Multrum™ system is based on one of the oldest principles in nature – simple organic decomposition.

about clivus multrum

The Clivus Multrum™ concept was developed in Sweden in the 1930's, and was the first compost toilet in the world.

The name 'Clivus Multrum™' actually translates as 'inclining compost room, and here in Australia, we have been selling these environmentally friendly toilet systems to people all over the country for over 30 years!

So it stands to reason that we know our product, and we understand our customer needs.

simple
organic
decomposition



clivus multrum





how does it work...

The Clivus Multrum™ system is based on a 'continuous' composting process in one large chamber, as opposed to multiple smaller chambers that require a restart of the process after emptying.

As the organic material decomposes it will reduce in volume by up to 90%.

The compost pile is therefore always 'shrinking in the middle' whilst new material is being added to the top, and finished compost is removed from the bottom of the pile as required.

continuous
composting
process

...which means that...

...it all decomposes!

As only one large composting chamber is used, the contents are in a more stable environment and are kept moist through normal use. In 'batch' systems where the full chamber must be moved away while the next chamber is being filled, the first chamber often dries out and does not fully decompose. This problem does not arise with a Clivus Multrum™!

... it's got a bigger capacity!

There is little risk of overfilling the composting chamber due to the Clivus Multrum's™ greater capacity, which makes it very tolerant to extremes in the rate of usage.

... there's no heavy lifting!

Only a relatively small amount of finished compost is removed at any one time.

This means there is no heavy lifting needed.

... you don't need any heaters!

A larger area of compost bed means there will be greater liquid evaporation without the use of heaters. Urine is well-treated by passing through the larger compost bed and converted to an innocuous liquid.

... there is less risk of mechanical problems!

The relatively simple design of the Clivus Multrum™ renders it far less susceptible to mechanical problems than other composting systems.



TOILET
Toilet room vented
through the pedestal

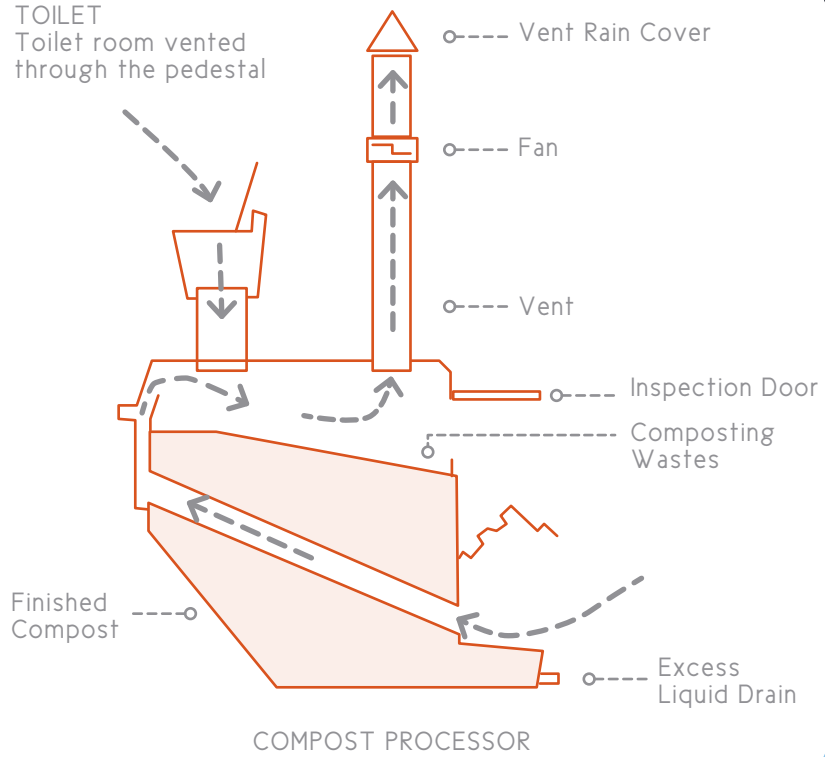

how it works





where can a clivus multrum be installed

Here are just some of the places where
you can install a Clivus Multrum™:-

- ▼ Domestic Households
- ▼ National Parks & Wildlife Services
- ▼ Permaculture Centres
- ▼ Roadside Rest Areas
- ▼ Camping Grounds
- ▼ Remote Communities
- ▼ Alpine Regions
- ▼ Environmental Education Centres
- ▼ Scout Associations
- ▼ Local Sporting Groups
- ▼ Tourist Lodges & Resorts

go green

The Clivus Multrum™ is 100% natural!

The decomposition process is a totally natural one. Chemicals are not used as they would only harm the various composting organisms.

pay less

The Clivus Multrum™ will save you money.

The Clivus Multrum™ uses absolutely no water, as against a conventional flush system, which can consume up to 30% of our household's total water usage.

With more and more councils imposing charges on water consumption, this saving converts to dollars staying in your pocket!

Plus the Clivus Multrum™ has easy access – this of course is essential should anything of value inadvertently fall down the toilet.

The Clivus Multrum™ provides easy access via the inspection door. With other systems often the only access is via the toilet chute making retrieval extremely difficult if not impossible.

no mess

The Clivus Multrum™ is easily cleaned – The toilet bowl is easily cleaned with biodegradable cleaner and a toilet brush. Because of its straight-through design, it actually needs less cleaning than a regular toilet bowl. The seat and the outside of the toilet can simply be wiped with some bio-degradable cleaner applied to a damp cloth.



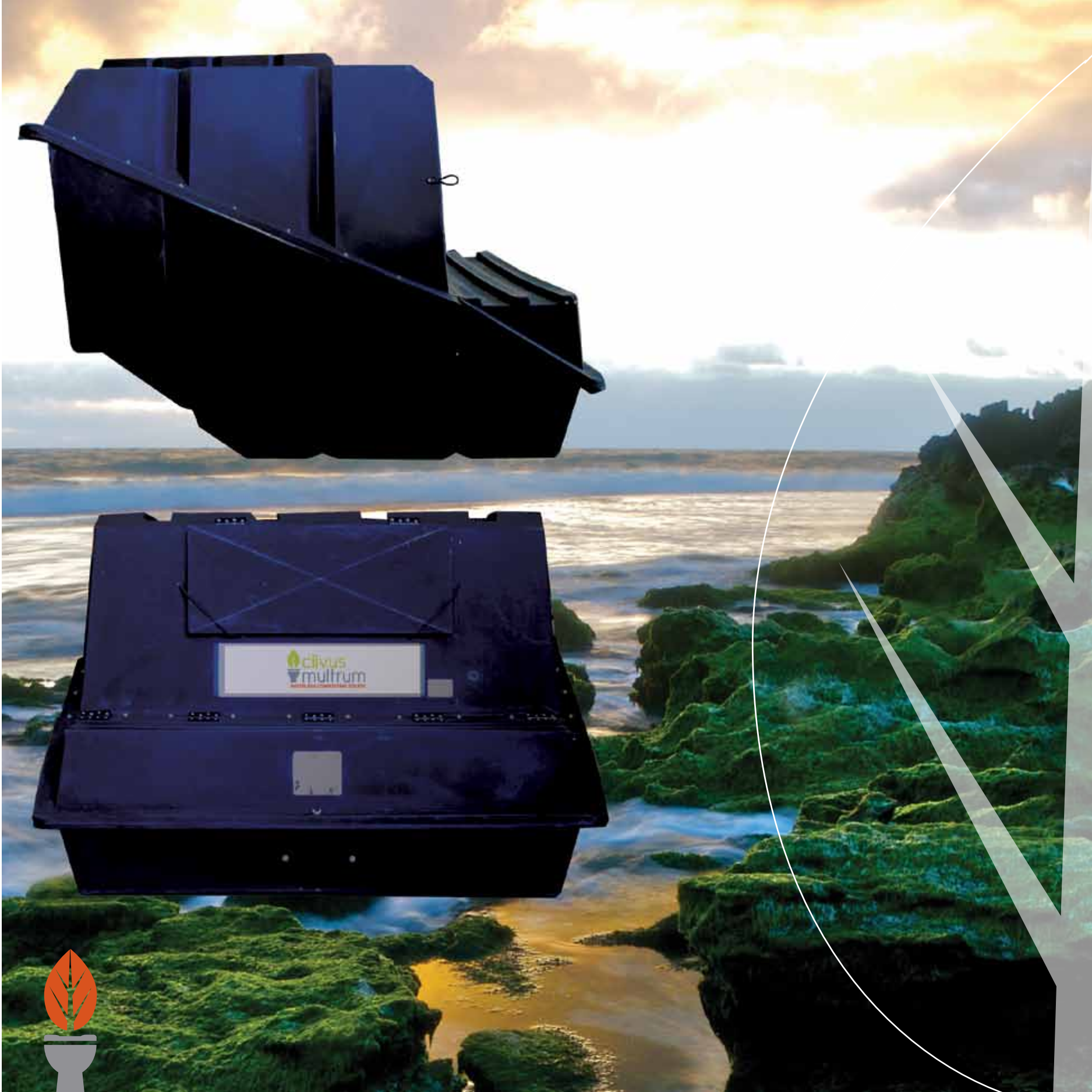



NOMINAL CAPACITY
 Daily | 20 visits (average)
 Annual | 8000 visits

The Clivus CM8 is ideal for typical domestic applications.

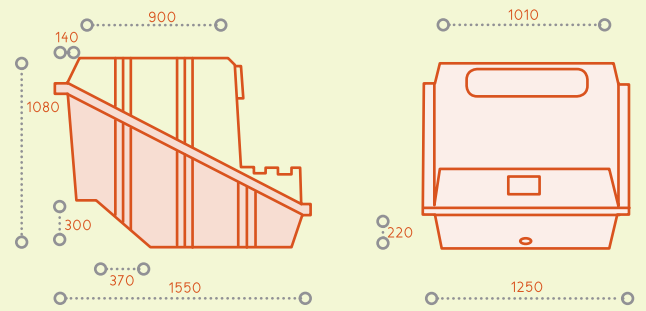

NOMINAL CAPACITY
 Daily | 25 visits (average)
 Annual | 10000 visits

The Clivus CM10 is ideal for domestic + small public applications, especially where two pedestals are required.

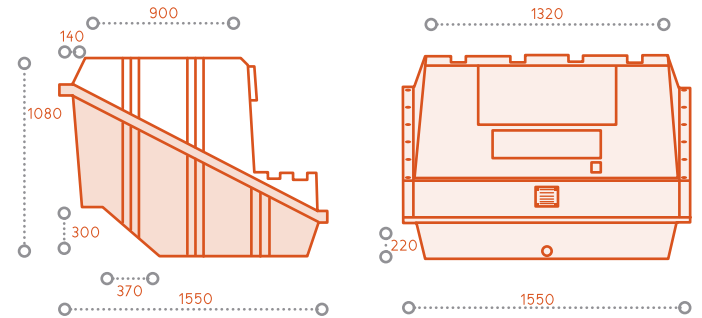

NOMINAL CAPACITY
 Daily | 38 visits (average)
 Annual | 14000 visits

The Clivus CM14 is ideal for larger households and small public facilities. The CM14 has the lowest profile of all the CM models when partially buried.

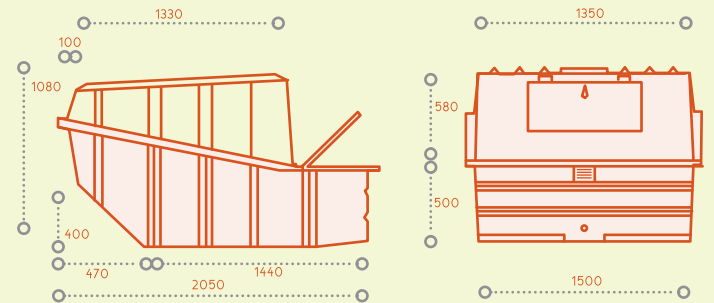

NOMINAL CAPACITY
 Daily | 55 visits (average)
 Annual | 20000 visits

The Clivus CM20 is ideal for large houses or small public facilities.

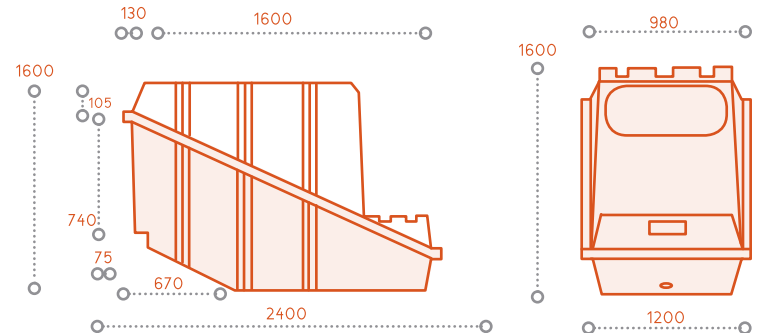

NOMINAL CAPACITY
 Daily | 110 visits (average)
 Annual | 40000 visits

The Clivus Multrum CM40 is ideal for medium to high usage public facilities, especially in locations where water is in short supply.

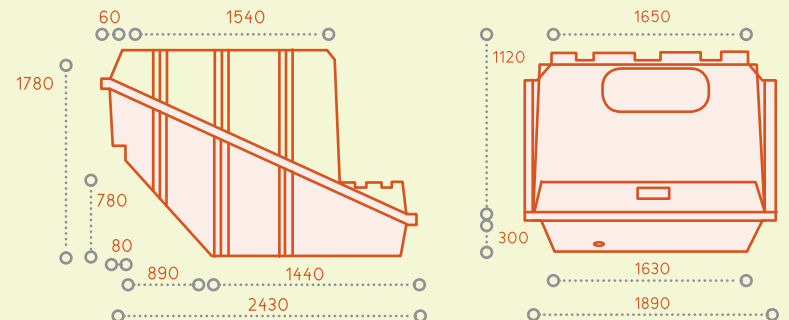

go green pay less no mess

MODEL	USES / YEAR	APPLICATIONS	DIMENSIONS mm	OTHER
CM8	8000	Small homes, holiday houses, walking trails, remote work stations.	Height = 1100 Length = 1550 Width = 1250	Min. clearance under floor = 1000 Max. buried in ground at front = 200 Max. fixtures = 1 pedestal
CM10	10 000	Family homes with more than one toilet, small public facilities	Height = 1100 Length = 1550 Width = 1550	Min. clearance under floor = 1000 Max. buried in ground at front = 200 Max. fixtures = 2 pedestals
CM14	14 000	Large sized family homes with more that one toilet, small public facilities	Height = 1100 Length = 2050 Width = 1500	Min. clearance under floor = 750 Max. buried in ground at front = 450 Max. fixtures = 2 pedestals
CM20	20 000	Larger homes with more than one toilet, small to medium sized public facilities	Height = 1630 Length = 2390 Width = 1200	Min. clearance under floor = 1400 Max. buried in ground at front = 300 Max. fixtures = 2 pedestals + 1 urinal
CM40	40 000	Larger public and commercial facilities, e.g. roadside stops and national parks	Height = 1780 Length = 2430 Width = 1890	Min. clearance under floor = 1700 Max. buried in ground at front = 300 Max. fixtures = 4 pedestals + 2 urinals
CM60	60 000	High public usage areas, e.g. tourist stops, camping areas.	Height = 2480 Length = 2430 Width = 1890	Min. clearance under floor = 2400 Max. buried in ground at front = 300 Max. fixtures = 4 pedestals + 2 urinals



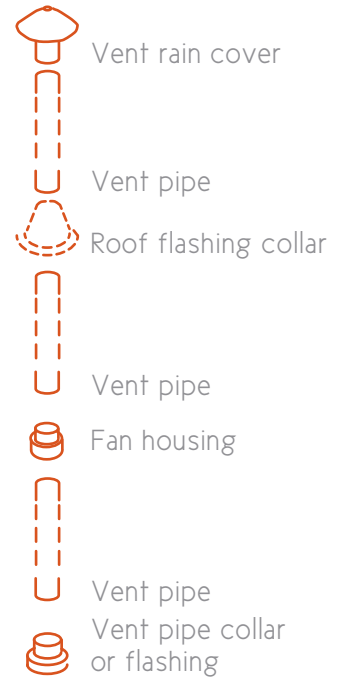
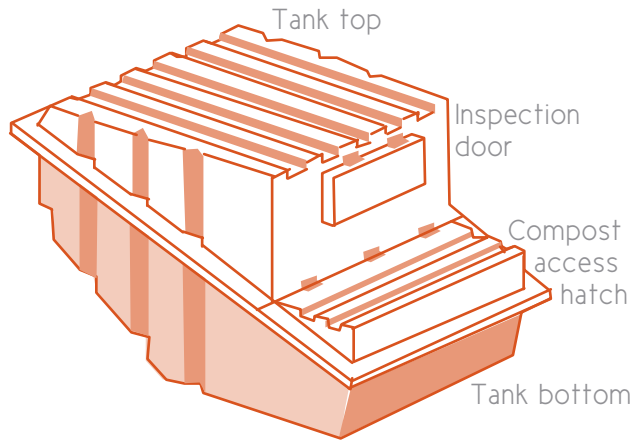

what you get

A standard Tank Package includes:

- Fully assembled composting tank
- Heavy duty 12 volt fan & 240V transformer.
- Vent pipe flashing, fan housing & vent rain cover. (150mm)
- Maintenance tool
- Starter bacteria
- Sealant & screws
- Installation Manual
- Operation & Maintenance Manual

A Pedestal Package includes:

- Toilet pedestal & seat
- Hold down bolts / screw
- Signs & stickers
- Toilet chute (0.7m) & collar

Vent & Drain Kit (optional)**

- Liquid drain pipe (1m)
- Absorption trench arch
- PVC Ventilation pipes (4.5m) & brackets
- Roof flashing collar

Bulking agent to start the process (e.g. wood shavings) is usually sourced locally, however we will also supply this upon request. Please note that diagram elements are not to scale.



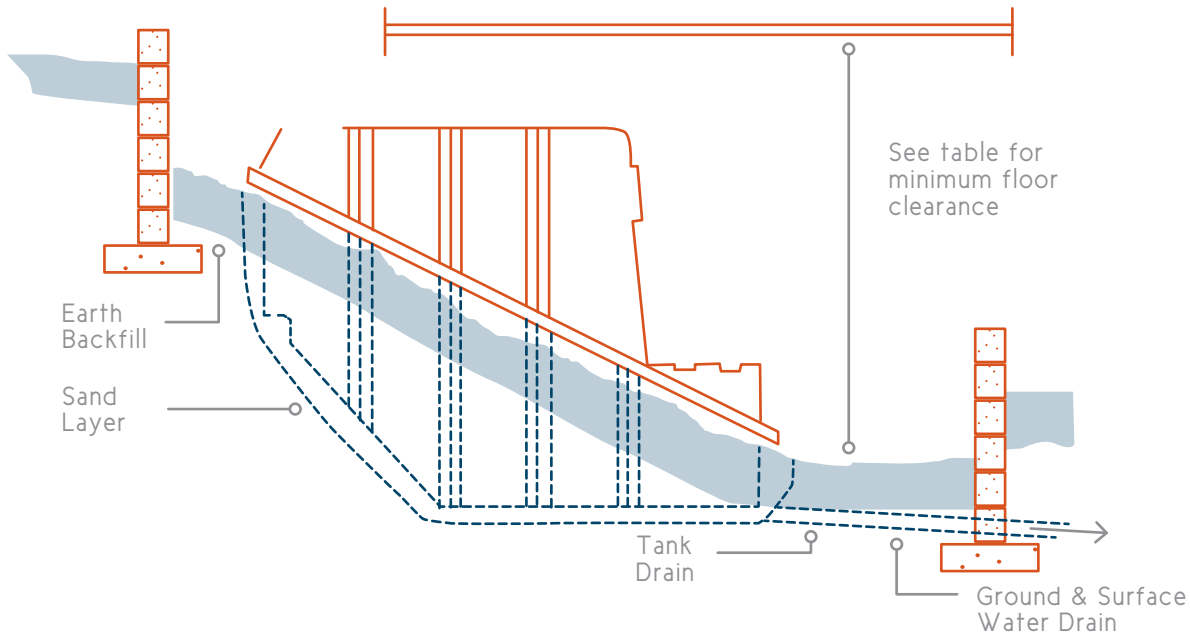

sloping site installations

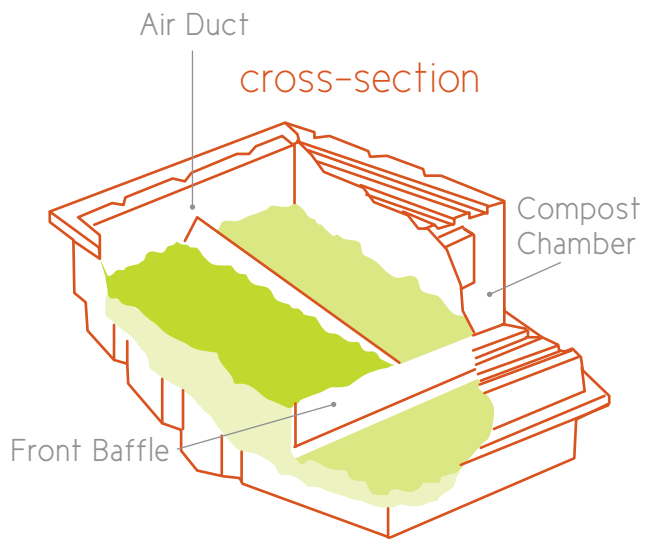

dual level application

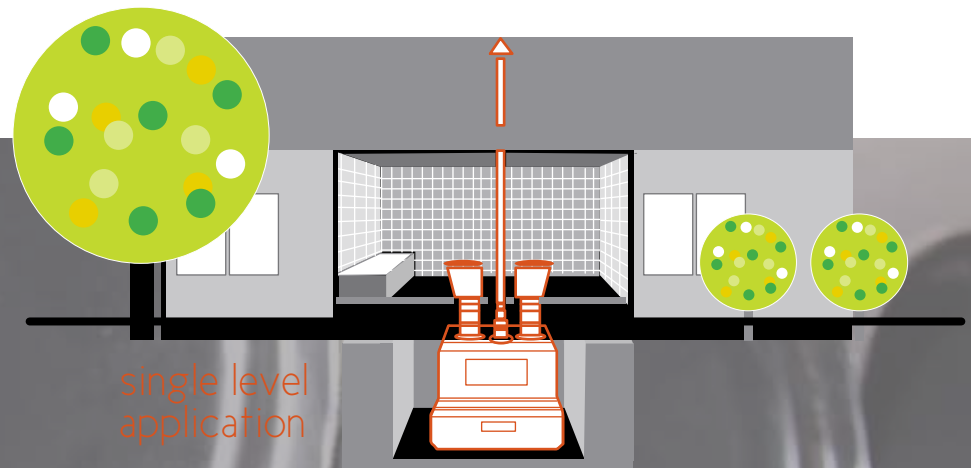
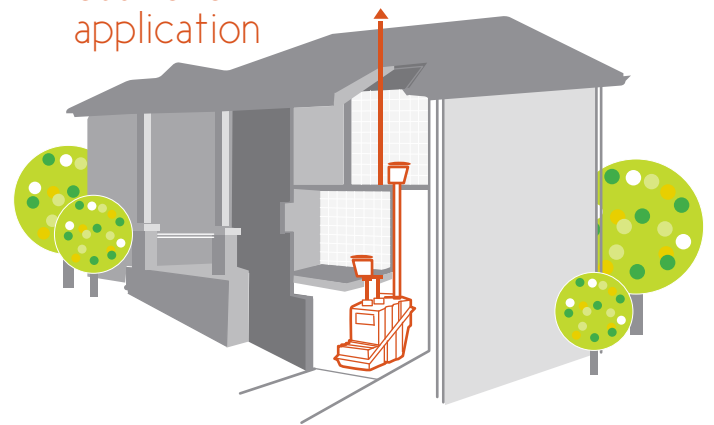



Proudly the
Australian distributor
for the great range of



p 1300 13 81 82

www.clivusmultrum.com.au

f 07 3889 6149

PO Box 5467 Brendale QLD 4500
3/14 Hinkler Court Brendale QLD 4500